

THIS DRAWING IS UNPUBLISHED. RELEASED FOR PUBLICATION, 19
 © COPYRIGHT 19 BY AMP INCORPORATED. ALL INTERNATIONAL RIGHTS RESERVED.

LOC	DIST	P	F	REVISIONS				
AF	50			ZONE	LTR	DESCRIPTION	DATE	APPD
					U	REDRAWN PER 0710-0005-95	07/APR/95	PF/GY

1 CONTINUOUS STRIP ON REEL.

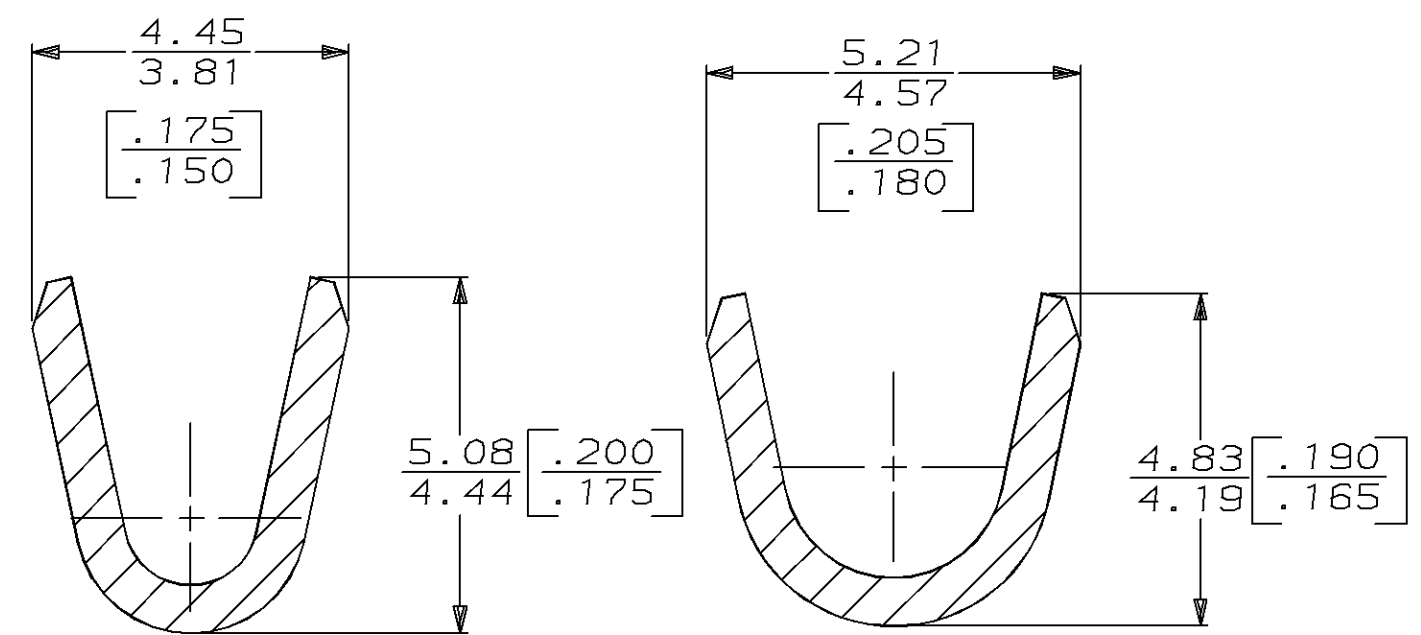
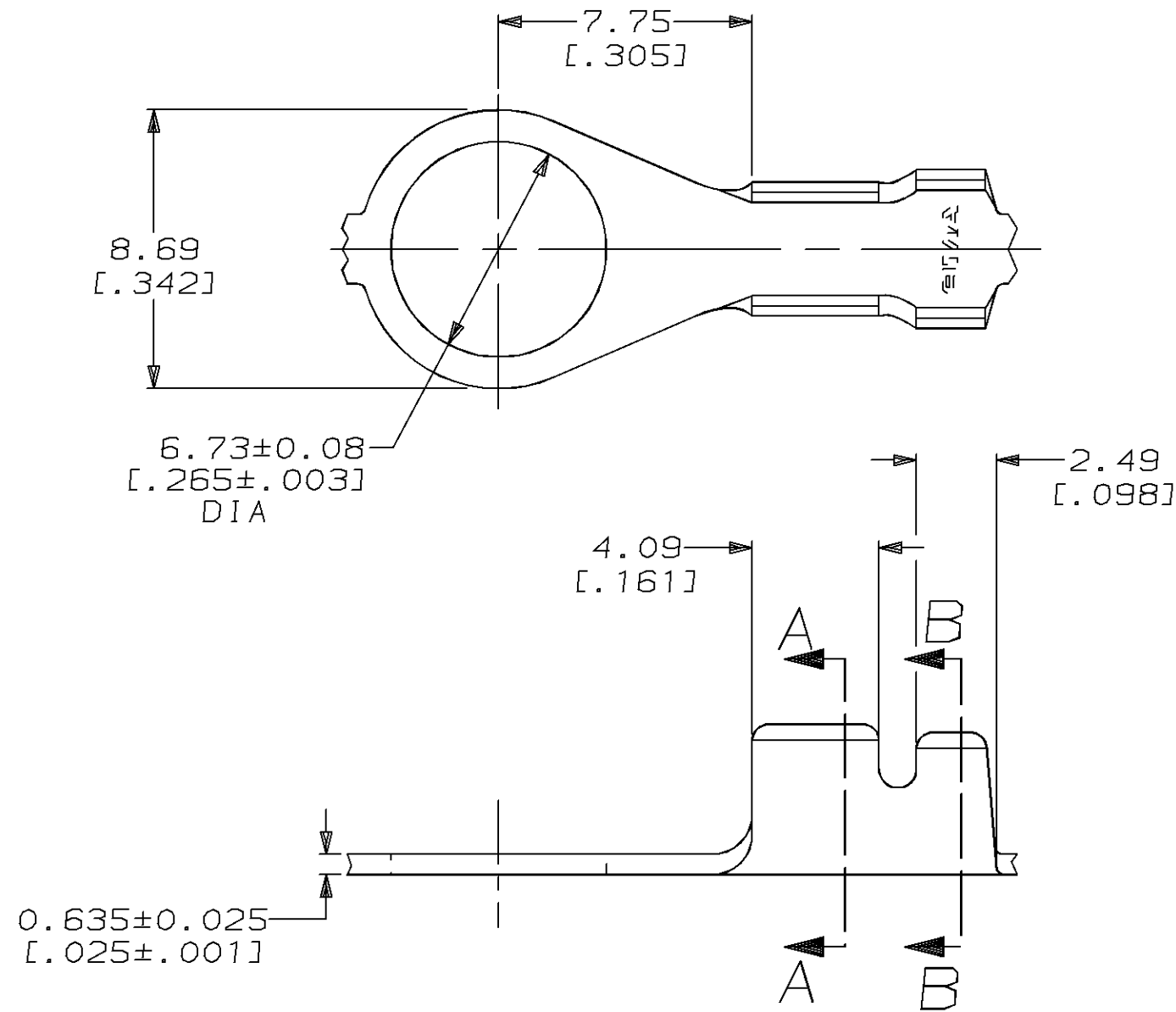

SECTION A-A
SCALE 10:1

SECTION B-B
SCALE 10:1

THIS DRAWING IS A CONTROLLED DOCUMENT FOR AMP INCORPORATED. IT IS SUBJECT TO CHANGE AND THE CONTROLLING ENGINEERING ORGANIZATION SHOULD BE CONTACTED FOR THE LATEST REVISION.

2.54-3.56 DIA [.100-.140]		[18-14] AWG	60625-1	
INSULATION RANGE		WIRE RANGE	PART NO	
DO NOT SCALE PRINT. UNLESS SPECIFIED DIMENSIONS IN mm [INCHES] TOLERANCES ON: 2 PLC DEC ± 0.25 [.010] 3 PLC DEC ± - ANGLES ± -	DR 07/APR/95 PHILLIP M FORTNEY	AMP AMP Incorporated Harrisburg, PA 17105-3608		
	CHK 07/APR/95 JEFF R RUTH			
	APPD 07/APR/95 GARY YETTER	NAME RING		
	APPD 07/APR/95 MARK BARNABA PRODUCT SPEC -			
MATERIAL 082 BRASS	APPLICATION SPEC -	SIZE B	CAGE CODE 00779	DRAWING NO C-60625
FINISH 0.002032 [.000080] MIN TIN PLATE PER MIL-T-10727	WEIGHT -	SCALE 5:1	SHEET 1 OF 1	